

COMMERCIAL



■ FLEXIBLE VENTING OPTIONS

- Concentric or Schedule 40 PVC/CPVC
- Direct Vent (Concentric and Twin Pipe)
- Non-Direct Vent (Room Air)
- Common Vent (Direct Vent and Room Air)
Vent lengths up to 150 Ft with eight Tankless Water Heater units.
- Maximum Equivalent Vent Lengths:

Twin Pipe

Vent Sizes	2 in. (51 mm)	3 in. (76 mm)
Vent Lengths	65 ft (20 m)	150 ft (46 m)

Concentric

Vent Sizes	2 in. X 4 in.	3 in. X 5 in.
Vent Lengths	65 ft (20 m)	150 ft (46 m)

■ OPTIONAL ACCESSORIES

Room Air Screen, Condensate Neutralizer, ScaleCutter, Control-R™ Wi-Fi Module, Wireless Accessories, and many more. Visit rinnai.us for a complete list of accessories.

■ EASE OF INSTALLATION AND SERVICEABILITY

- Wi-Fi Technology for Remote Monitoring and Management
- Simple Gas Conversion

SUPER-HIGH-EFFICIENCY (CONDENSING) HYBRID WATER HEATING SYSTEM

Installation Type	Internal (Indoor) Commercial Applications
Model Numbers	CHS199100CU
Approved Gas Types	Natural and Propane
Maximum Gas Consumption	199,000 BTU/h
Thermal Efficiency	Up to 97%
First Hour Delivery (100°F Rise)	315 Gallons (1192 L)
High Altitude Approved	Up to 10,200 Ft (3,109 M)
Tank Capacity	119 Gallons (450 L)
Water Flow Control	Water Flow Sensor, Electronic Water Control and Bypass Control
Controller	Standard: Integrated Controller Optional: MC-91-2US
Certifications	AHRI, ANSI Z21.10.3, CSA 4.3, and Energy Star®

Storage Tank

- 2" Eco-friendly foam insulation
- Glass-lined inner tank
- 1-1/2" MNPT dielectric hot and cold connections
- Pre-installed temperature & Pressure relief valve
- Brass drain valve
- Dual magnesium anode rods
- Hand hole clean-out

Warranty

- Heat Exchanger: 8 years or 12,000 operation hours, whichever occurs first
- Tank: 6 years
- All Other Parts and Components: 5 Years
- Reasonable Labor: 1 Year
(Refer to the Installation and Operation Manual for further warranty information.)

Safety Devices

Flame Failure - Flame Rod, Boiling Protection, Combustion Fan RPM Check, Over Current - Glass Fuse, Remaining Flame (OHS) and Automatic Frost Protection

Additional Features

- Complies with South Coast Air Quality Management District 14 ng/J or 20 ppm NOx Emission Levels
- Ultra Low NOx
- Tankless Rack System™ Compatible
- 1/2 in. (13 mm) Gas Line Compatible



CERTIFIED TO ANSI Z21.10.3 — CSA 4.3

TECHNICAL SPECIFICATIONS

SPECIFICATION		CHS199100CU
Product Description		Condensing Hybrid System: Condensing Tankless, Insulated Storage Tank, Pump & Control
Minimum Gas Consumption Btu/h (kW/h)		15,000 (4.5)
Maximum Gas Consumption Btu/h (kW/h)		199,000 (58.3)
Tank Volume		119 Gallons (450 Liters)
Thermal Efficiency (CU199i)		Up to 97%
Uniform Energy Factor (UEF)		CU199i: 0.93
Weight		431 lb (195 kg)
Sound Level		49 dB
Electrical	Normal	265 W
	Standby	44 W
	Freeze Protection	148 W
	Max Current	5.5 Amps
	Fuse	Tankless Engine: 10 Amps, System Controller 10 Amps
Temperature		<ul style="list-style-type: none"> Minimum: 98° F (37° C) Default Maximum: 140° F (60° C) Default 185° F (85° C) With Parameter Adjustment
By-Pass Flow Control		Electronic
Gas Supply Pressure ²		<ul style="list-style-type: none"> Natural: 3.5 in. w.c. - 10.5 in. w.c. Propane: 8.0 in. w.c. - 13.5 in. w.c.
Ignition System		Direct Electronic Ignition
Electronic Connections		<ul style="list-style-type: none"> Appliance: AC 120 Volts, 60Hz. Temperature Controller: DC 12 Volts (Digital)
Water Supply Pressure		<ul style="list-style-type: none"> Maximum: 150 PSI
Service Connections		<ul style="list-style-type: none"> Gas Supply: 3/4 in. (19 mm) NPT Cold Water Inlet: 1-1/2 in. (mm) NPT Hot Water Outlet: 1-1/2 in. (19 mm) NPT Condensate Drain: 1/2 in. (13 mm) (SOCKET)

DIMENSIONS

INCHES

TOP

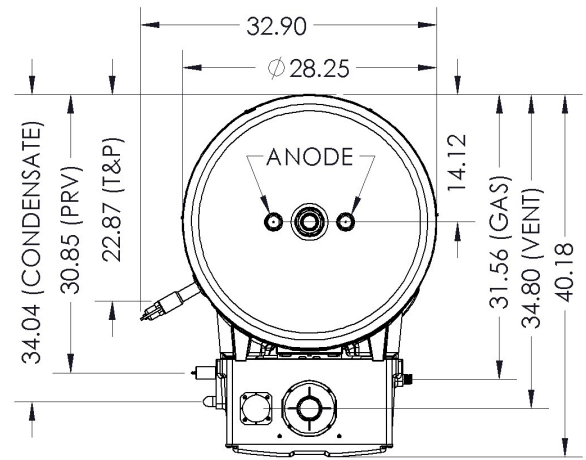

FRONT

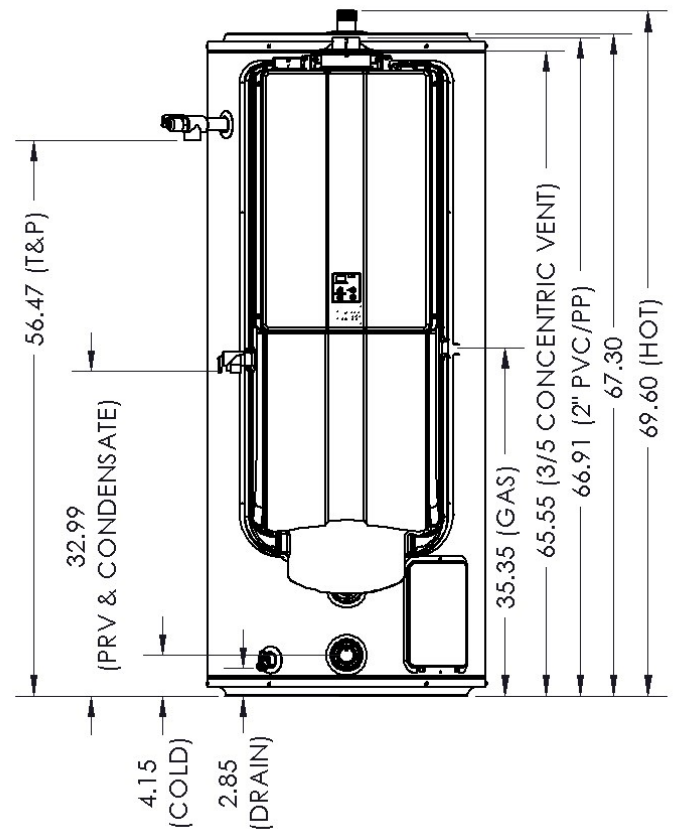

RECOVERY CAPACITIES

RECOVERY CAPACITIES													
Tank Capacity	U.S. GALLON/HR LITERS/HR AT TEMPERATURE RISE INDICATED												
	°F	30°F	40°F	50°F	60°F	70°F	80°F	90°F	100°F	110°F	120°F	130°F	140°F
	°C	17°C	22°C	28°C	33°C	39°C	44°C	50°C	56°C	61°C	67°C	72°C	78°C
119 U.S. Gals.	GPH	772	579	463	386	331	289	257	232	211	193	178	165
450 Liters	LPH	2922	2192	1753	1461	1253	1093	973	878	799	731	673	625